

PROBE Ver.14

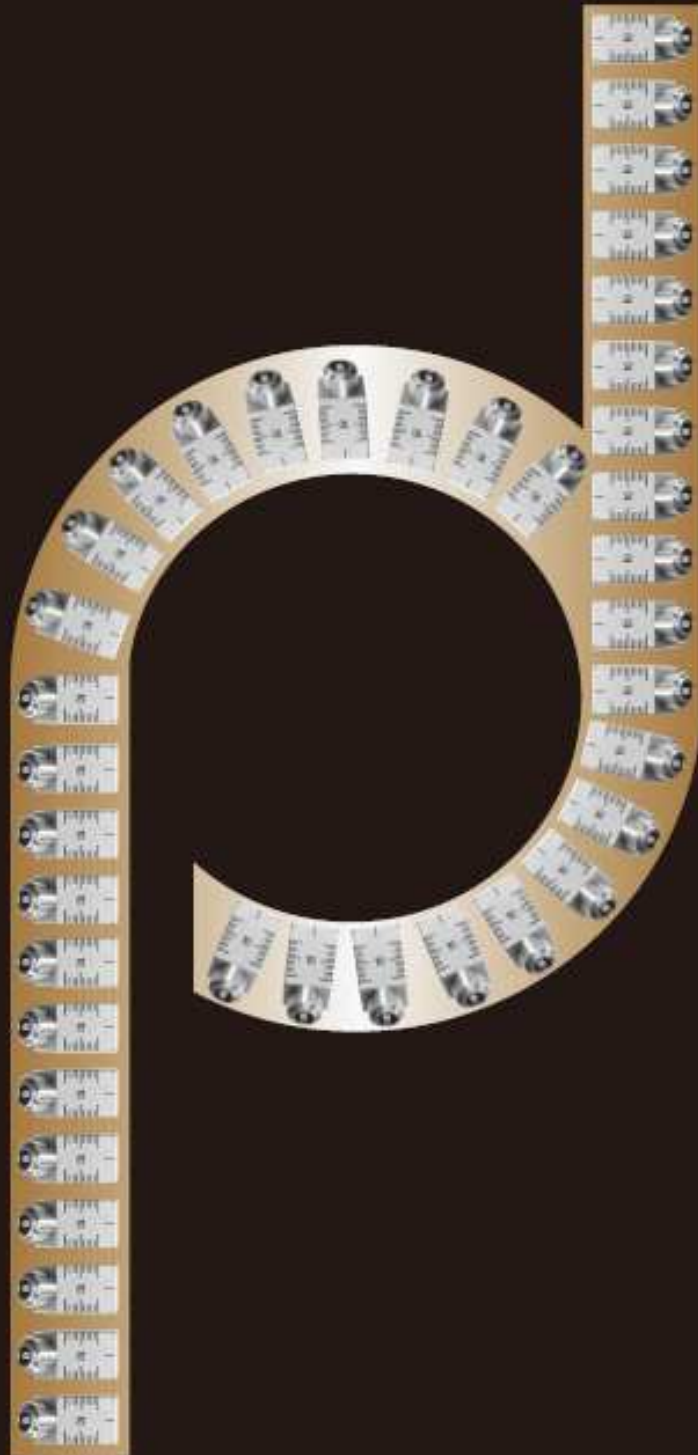

Leading Future by High Tech
JAPAN PROBE CO., LTD.

index

General Description

[General Description] 2

Standard Probe

[Angle Beam Probe] 3
Standard /

[Angle Beam Probe] 4
Surface Beam SH Wave Probe /
Probe for Footing Depth Measurement /
Angle Beam SH Wave Probe /
Surface Wave Probe /

[Angle Beam Probe] 5
Longitudinal Wave Angle Beam Probe /
Angle Beam Probe for Aluminum Detection /
Probe for Gas Pressure Welding Zone of
Reinforcing Bar /
Probe for Mechanical Joint of Bar /
Probe for Welding Zone of Reinforced
Concrete Deformed Bar /

[Dual Element Angle Beam Probe] 6
Dual Element Shear Wave Angle Beam Probe /
Dual Element Longitudinal Wave Angle Beam
Probe /
Creeping Wave Probe /

[Straight Beam Probe] 7
Circle /
Square /
Immersion Probe /

[Straight Beam Probe] 8
Dual Element Straight Beam Probe /
Delay Material Faced Straight Beam Probe /
Shear Wave Straight Beam Probe /

[Broadband Probe] 9
Straight Beam Probe / Low Frequency Probe
Immersion Probe /

Angle Beam Probe /
[Composite Probe] 10

Immersion Probe /
Angle Beam Probe /
Longitudinal Wave Angle Beam Probe /
Dual Element Angle Beam Probe /
Dual Element Longitudinal Wave Angle Beam Probe /

[Focusing Probe] 11
Point Focusing Angle Beam Probe /
Point Focusing Longitudinal Wave Probe /
Broadband Point Focusing Angle Beam Probe /

[Focusing Probe] 12
Point Focusing Straight Beam Probe /
Point Focusing Immersion Probe /
Broadband Point Focusing Immersion Probe /

[Focal Range Data List] 13

[Performance Testing of Point Focusing Probe] 14

Special Probe

[SOFT PROBE 「JUTAN」] 15
Flat Type / Case Type / Pencil Type /
Single Element Straight Beam /

Dual Element Straight Beam /
[SOFT PROBE 「JUTAN」] 16

Cartridge Type /
Single Element Straight Beam /
Dual Element Straight Beam /

[FLEXIBLE PROBE 「TAKOTAN」] 17
Single Element Straight Beam /
Dual Element Straight Beam /

[Variable Angle Probe / Magnetic Probe] 18
Variable Angle Probe /
Magnetic Probe /

[Small Probe / Slim Probe] 19
Small Probe /
Slim Probe /

[Insertion Probe / Pencil Type Probe] 20
Insertion Probe /
Pencil Type Probe /

[High Frequency / High Temperature Probe] 21
High Frequency Probe /
High Temperature Probe /
High Temperature Straight Beam Probe /
High Temperature Dual Element Straight Beam Probe /
High Temperature Angle Beam Probe /

[Pressure-resistant Probe] 22
Pressure-resistant Probe /

[Tire Probe] 23
Single Element Fixed Probe /
Dual Element Fixed Probe /

[Jig/Wedge/Couplant] 24
Jig / Wedge / Couplant /

[Ultrasonic Array Probe] 25
Ultrasonic Array Probe /
Array Probe Related Products /

[Ultrasonic Array Probe] 26
Flexible Linear Array Probe 「KYOKUTAN」 /
Plactical example of Hemispherical Array Probe/

Detecting Device

[Non-contact Air coupled Ultrasonic Testing Device] 27
NAUT(Non-contact Air coupled Ultrasonic Testing)/

[Non-contact Air coupled Ultrasonic Testing Device] 28
NAUT21 Solution examples /

[Non-contact Air coupled Ultrasonic Testing Device] 29
NAUT21 Software /
NAUT21 Line-up & Customizations /

[AIR PROBE] 30
Flat Type (High Sensitivity) /
Line Focus Type (High Sensitivity) /
Point Focus Type (High Sensitivity) /

Ultrasonic Pulsar/Receiver

[Ultrasonic Pulsar/Receiver] 31

Ultrasonic Propagation Simulator

[Ultrasonic Propagation Simulator] 32

Probe Cable

[Probe Cable] 33

Conversion Connector

[Conversion Connector] 34

G
·
D

S
·
P

S
·
P

D
·
D

U
·
P
/
R

U
·
P
·
S

P
·
C

C
·
C

General Description

Description

Probe : Electroacoustic switchboard with ultrasonic signal transmitting and receiving for the insertion of one or more vibrators. The diagram below provides the designators of JIS Z 2350

Designators for Probe (JIS Z 2350)

Order	Contents	Items / Marks
1	Frequency Bandwidth	Broadband : B, Narrowband : N, Refer to (※1)
2	Frequency	Unit for Nominal Frequency : MHz
3	Element Materials	Quartz : Q, Lead Zirconium Titanite Ceramics : Z, Piezoelectric Ceramics but Z : C, Polymer System : P, Composite : K, Etc. : F. In case of not specifying materials : M
4	Element Dimensions	Circle : Diameter (Unit : mm) In dual element, it indicates each element dimension (※2) Square : Height × Width (Unit : mm) (※3)
5	Waveform Mode	Longitudinal Wave : L (※4), Shear Wave : S (※5), SH Wave : H, Surface Wave : R
6	Type	Straight : N, Angle : A, Variable Angle : V, Immersion : I, Tire : W Dual Element Type : Adding "D"
7	Refraction Angle	It's represented by nominal refraction angle of low carbon steel, and the unit is degree (°), For materials, Adding the marks representing materials is another example.
8	Focusing Depth or Convergence Distance	Point Focusing : PF, Line Focusing : LF In case of dual element type having an intersection point, the depth unit is represented as "mm" after adding "F".

(※1) Optional (※2) Element dimensions of dual element probe

(※3) Element dimensions of single element angle probe

[Straight Beam Probe]

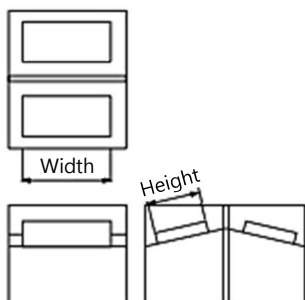

[Angle Beam Probe]

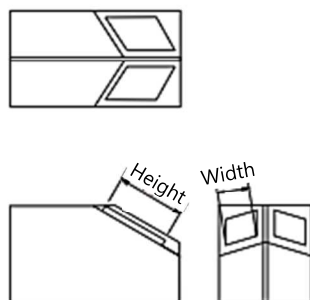

[Single Element Angle Probe]

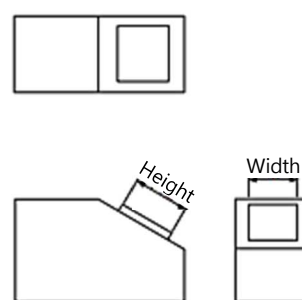

【Ex】

Name	Model	Connector		External Dimensions (mm)
		Type	Position	
AS	5Z 10×10 A45	LEMO (S) G51	Up/Back/Angle	14 X 25 X 20
	A60			
	A65			
	A70			

Frequency → Element Materials → Element Dimensions → Mode → Refraction Angle

【Marking Method of Probe】

2Z20N : 2MHz straight beam probe using the lead zirconium titanite ceramics element at $\Phi 20\text{mm}$

5Z10/2NDF10 : 5MHz dual element straight beam probe using the $\Phi 10\text{mm}$ lead zirconium titanite ceramics element separated semicircularly having the convergence distance at 10 mm

5C10×10A70 : 5 MHz angle beam probe having the refraction angle at 70 degrees using the lead zirconium titanite ceramics element at 10 mm height and 10 mm wide

B10K5I : 10 MHz broadband immersion probe using the composite element at $\Phi 5\text{ mm}$

G
·
D

S
·
P

S
·
P

D
·
D

U
·
P
/
R

U
·
P
·
S

P
·
C

C
·
C

Angle Probe

Standard Type

Name	Model	Model		External Dimensions W L H (mm)
		Type	Position	
AS	5Z10×10A45	LEMO (S) G51	Up/Back/Angle	14×25×20
	A60			
	A65			
	A70			

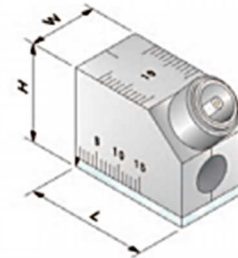

Connector Position : Angle

Name	Model	Model		External Dimensions W L H (mm)
		Type	Position	
AO	2C10×10A45	LEMO (S) G51	Up/Back/Angle	14×28×24
	A60			
	A65			
	A70			
	2C14×14A45			18×30×25
	A60			
	A65			
	A70			
	2C20×20A45			24×35×25
	A60			
	A65			
	A70			
	5C10×10A45			24×45×27
	A60			
	A65			
	A70			
5C14×14A45	14×25×20			
A60				
A65				
A70				
5C14×14A45	18×30×26			
A60				
A65				
A70				

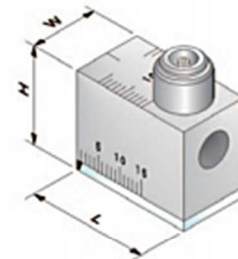

Connector Position : Up

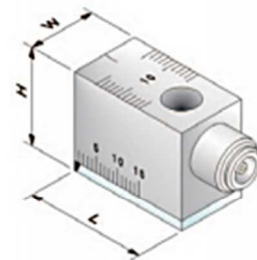

Connector Position : Back

AS/AO/JS

Name	Model	Model		External Dimensions W L H (mm)
		Type	Position	
JS	1Z20×20A45	LEMO (S) G51	Up/Back/Angle	24×35×25
	A60			24×45×27
	A70			14×25×20
	5C 5×10A45			
	A60			
	※ A65			
	A70			24×35×25
	5Z20×20A45			
	A60			
	A70			

※ Probe for welding zone of beam end

Name	Model	Model		External Dimensions W L H (mm)
		Type	Position	
JM	5C 5× 5A45	LEMO (S) G51/C25	Up/Back	8×12×15.5
	A60			
	A70			

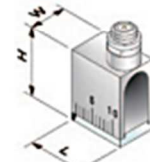

JM

Name	Model	Model		External Dimensions W L H (mm)
		Type	Position	
JG	5C 5× 5A45	LEMO (S) G51/C25	Up/Back	8×12×20.5
	A60			
	A70			



JG



JG2

Name	Model	Model		External Dimensions W L H (mm)
		Type	Position	
JG2	5C 5× 5A45	LEMO (S) G51/C25	Up/Back	11×12×20
	A60			
	A70			

Order Method	Name - Model - Connector - Connector Position
(Ex)	AS - 5Z10×10A45- G51 - Angle

- Connector
- LEMO(S) : ERA00250 , LEMO company
 - G51 : GS-BR-NI3 , DDK company
 - C25 : MICRODOT company



C25

G
·
D

S
·
P

S
·
P

D
·
D

U
·
P
/
R

U
·
P
·
S

P
·
C

C
·
C

Angle Probe

Surface Beam SH Wave Probe

Name	Model	Model		External Dimensions W L H (mm)
		Type	Position	
JRY	2Z 5× 5HA90	C25	Up/Back	8×16×15
	5Z 5× 5HA90			
	2Z10×10HA90			
JYS2	5C10×10HA90	LEMO (S) G51/C25	Up/Back/Angle	14×25×20
	5Z 5× 5HA90			
	5C10×10HA90			

JYS2 is the probe adding the groove for shoe.

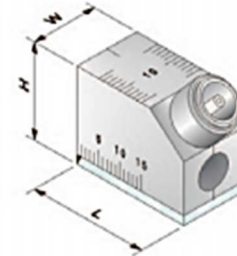

Connector Position : Angle

Probe for Footing Depth Measurement

Name	Model	Model		External Dimensions W L H (mm)
		Type	Position	
JRY	0.5Z20×20HA90	LEMO (S) G51	Up/Back/Angle	28×30×25

The round shape chamfering is available.

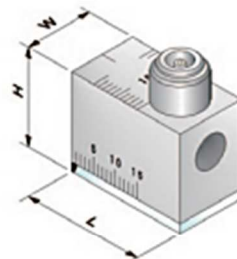

Connector Position : Up

Angle Beam SH Wave Probe

Name	Model	Model		External Dimensions W L H (mm)
		Type	Position	
JY	2Z10×10HA45	LEMO (S) G51	Up/Back/Angle	14×25×20
	HA60			
	HA70			
	5Z 5× 5HA45	LEMO (S) G51/C25	Up/Back/Angle Up/Back ※	14×25×20 8×16×15※
	HA60			
	HA70			
	5C10×10HA45	LEMO (S) G51	Up/Back/Angle	14×25×20
	HA60			
	HA70			

※ It's limited to C25

The couplant reserved is required to use SH wave probe.

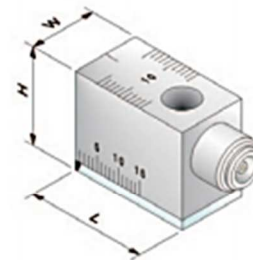

Connector Position : Back

Surface Wave Probe

Name	Model	Model		External Dimensions W L H (mm)
		Type	Position	
JR	2Z10×10R	LEMO (S) G51/C25	Up/Back/Angle	14×25×20
	2Z20×20R			
	5Z10×10R			

JRY/JYS2 (Adding the groove For shoe)
JY/JR

Order Method	Name	Model	Connector	Connector Position
(Ex)	JRY	5Z5×5HA90	C25	Angle

G
·
D

S
·
P

S
·
P

D
·
D

U
·
P
/
R

U
·
P
·
S

P
·
C

C
·
C

Angle Probe

G
·
D

S
·
P

S
·
P

D
·
D

U
·
P
/
R

U
·
P
·
S

P
·
C

C
·
C

Longitudinal Wave Angle Beam Probe

Name	Model	Model		External Dimensions W L H (mm)
		Type	Position	
JL	2C10×10LA45	LEMO (S) G51	Up/Back	15×30×39
	LA60			
	2C20×20LA45		Up/Back	30×45×50
	LA60			
	5C10×10LA45		Up/Back	15×30×39
	LA60			
5C20×20LA70	Up/Back	30×45×50		

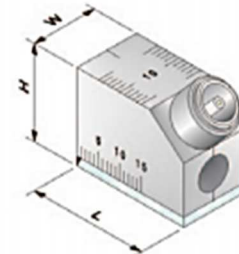

Connector Position : Angle

Angle Beam Probe for Aluminum Detection

Name	Model	Model		External Dimensions W L H (mm)
		Type	Position	
JA	5C10×10A45AL	LEMO (S) G51	Up/Back /Angle	14×25×20
	A60AL			
	A70AL			

JA : In case of aluminum, it's manufactured by setting the shear wave velocity at 3150 m/s with anisotropy & anisotropy of velocity into consideration.

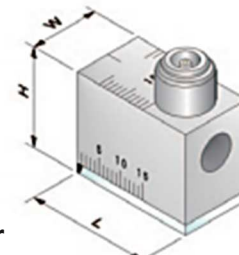

Probe for Gas Pressure Welding Zone of Reinforcing Bar

Detecting Surface : FLAT/R16

Name	Model	Model		External Dimensions W L H (mm)
		Type	Position	
AG	5Z 5x5 A70, or A70 R16	LEMO (S) G51	Up/Back	11×16.5×26
AG2	5Z 5x5 A70, or A70 R16			11×12×20

Connector Position : Up

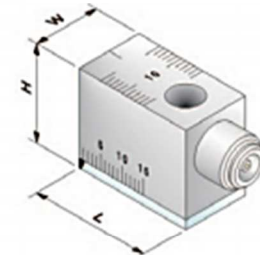

Probe for Mechanical Joint of Bar (Product suitable for JRJS 0003)

Detecting Surface : FLAT/R16

Name	Model	Model		External Dimensions W L H (mm)
		Type	Position	
JSV	5C10× 5A80	LEMO (S) G51/C25	Up/Back	10×25×20
	5A80R16			
	5C10× 10A80	LEMO (S) G51	Up/Back /Angle	14×25×20
	10A80R16			

Connector Position : Back

JL/JA/JSV

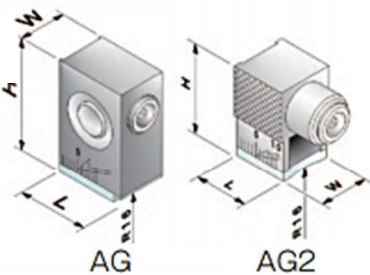

Probe for Welding Zone of Reinforced Concrete Deformed Bar (Product suitable for JRJS 0005)

Detecting Surface : FLAT/R16

Name	Model	Model		External Dimensions W L H (mm)
		Type	Position	
A2F	5C(5×5)×2A70	LEMO (S) G51	Up/Back	14×17×21
	2A70R16			

The requirements above is subject to change without notice.



Order Method	Name	Model	Connector	Connector Position
(Ex)	JL	5C10×10LA45	LEMO(S)	Up

Dual Element Angle Beam Probe

■ Dual Element Shear Wave Angle Beam Probe

Name	Model	Connector		External Dimensions W L H (mm)
		Type	Position	
JD	2C10× 7AD45	LEMO (S) G51/C25	Up/Back	22×30×25
	AD60			
	2C10×10AD45			28×30×25
	AD60			
	5C 5× 5AD45	C25	Up/Back /Angle	14×25×20
	AD60			
	AD70			
	5C10× 5AD45			
	AD60	LEMO (S) G51/C25	Up/Back	22×30×25
	AD70			
	5C10×10AD45			28×30×25
	AD60			
AD70				

Please, contact us to inquire about the convergence distance.

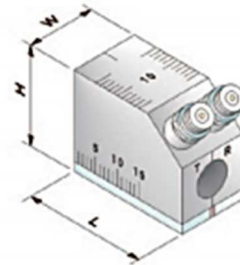

Connector Position : Angle

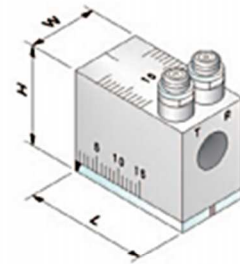

Connector Position : Up

■ Dual Element Longitudinal Wave Angle Beam Probe

Name	Model	Connector		External Dimensions W L H (mm)
		Type	Position	
JDL	2C10× 7LAD45	LEMO (S) G51/C25	Up/Back	22×30×25
	LAD60			
	2C10×10LAD45			28×30×25
	LAD60			
	2C20× 10LAD45	C25	Up/Back /Angle	14×25×20
	LAD60			
	LAD70			
	5C10× 5LAD45			
	LAD60	LEMO (S) G51/C25	Up/Back	22×30×25
	LAD70			
	5C10×10LAD45			28×30×25
	LAD60			
LAD70				

Please, contact us to inquire about the convergence distance.

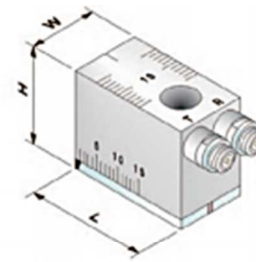

Connector Position : Back

JD/JDL

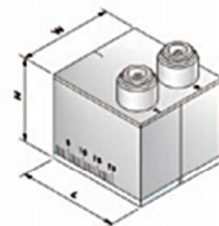

Connector Position : Up

■ Creeping Wave Probe

Name	Model	Connector		External Dimensions W L H (mm)
		Type	Position	
JC	2Z20×10LAD90	LE/G51/C25	Up/Back	24×35×24
	5Z10× 5LAD90	C25	Up/Back /Angle	14×25×20
	5Z10×10LAD90	LEMO (S) G51/C25	Up/Back	28×30×25
	5Z15×10LAD90			

Order Method

Name — Model — Conv. Distance — Connector — its Position
(Ex) JD — 5C10×10AD70 — F10 — G51 — Up

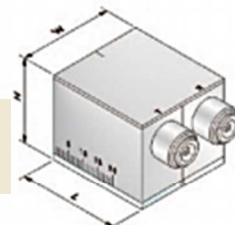

Connector Position : Back

JC

G · D

S · P

S · P

D · D

U · P / R

U · P · S

P · C

C · C

Straight Beam Probe

G
·
D

S
·
P

S
·
P

D
·
D

U
·
P
/
R

U
·
P
·
S

P
·
C

C
·
C

Circle

Name	Model	Connector		External Dimensions Φ H (mm)
		Type	Position	
PN	1C20N	LEMO (S) G51/C25	Up/Side	26×35
	30N			34×36
	2C10N			14×20
	20N			24×28
	30N			34×36
	5C 5N			14×20
	10N			24×28
	20N			24×28
	10C 5N			14×20
	10N			14×20

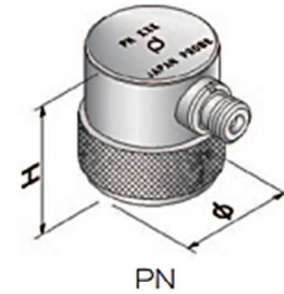

Name	Model	Direct Output of Cable		External Dimensions Φ H (mm)
		Type	Position	
PNS	5C 5N	LEMO (L) LEMO (S) BNC	Side	8×10
	10C 5N		Up/Side	8×25
	5C 5N			14×20
	10N			8×25
	10C 5N			8×25



Square

Name	Model	Connector		External Dimensions Φ H (mm)
		Type	Position	
PK	2C10N	LEMO (S) G51/C25	Up/Side	15.5×19
	20N			33×36.5
	5C10N			15.5×19
	20N			33×36.5

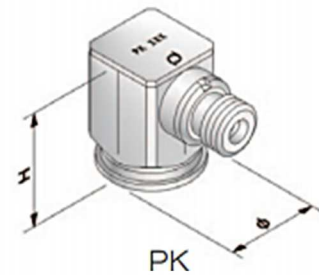

This probe is the type available to attach the protection rubber, and we ensure the performance as the point before attaching the protection rubber.

Immersion Probe

Name	Model	Direct Output of Cable		External Dimensions Φ H (mm)
		Type	Position	
IN	2C10I	LEMO (L) LEMO (S) BNC	Up	14×25
	20I			24×28
	5C 5I			8×25
	10I			14×25
	20I			24×28
	10C 5I			8×25



In case of "PN", "PNS", "PK", "IN", the element materials, "Z" can be made.

Order Method	Name	Model	Connector	Connector Position
(Ex)	PN	5C20N	G51	Side

When you order "Immersion Probe",

Order Method	Name	Model	Cable	Connector	Cable Position
(Ex)	IN	5C10I	Direct Contact, 2m	LEMO(L)	Up

Straight Beam Probe

Dual Element Straight Beam Probe

Name	Model	Connector		External Dimensions Φ H (mm)
		Type	Position	
PD	2C10/2ND F10	C25	Up/Side	14×22
	20/2ND F15	LE/G51/C25		24×30
	5C 5/2ND F 5	C25		8×20
	10/2ND F10			14×22
	20/2ND F15			24×30
10C 5/2ND F 3	C25	8×20		

Name	Model	Connector		External Dimensions Φ H (mm)
		Type	Position	
PDS	2C10/2ND F10	LEMO (L) LEMO (S) BNC	Up/Side	14×22
	20/2ND F15			24×30
	5C 5/2ND F 5			8×20
	10/2ND F10			14×22
	20/2ND F15			24×30
10C 5/2ND F 3		8×20		

Name	Model	Connector		External Dimensions W L H (mm)
		Type	Position	
PG	5C3×20ND F10 5C4×20ND F10	LE/G51/C25	Up/Side	22×30×30

Please, contact us to inquire about the convergence distance beyond that related to the above information.

In case of "PD", "PDS", "PG", the element materials, "Z" can be made.

Delay Material Faced Straight Beam Probe

Name	Model	Connector		External Dimensions Φ H (mm)
		Type	Position	
PNH	5C 5N DL10	LEMO (S) G51/C25	Up/Side	12×30
	10N DL10			12×30
	10C 5N DL10			12×30

* Delay material: polystyrene

Please contact us to inquire specifications other than the above.

Name	Model	Connector		External Dimensions W L H (mm)
		Type	Position	
PKH	5C10N H25	LEMO (S) G51/C25	Side	16×16×50
	H40			16×16×65
	H60			16×16×75
	5C20N H25			26×26×52
	H50			26×26×75

* Delay material material: polyetherimide

In case of "PNH" & "PKH", the element materials, "K" can be made.

Shear Wave Straight Beam Probe

Name	Model	Connector		External Dimensions W L H (mm)
		Type	Position	
PY	0.5Z20×20SN	LEMO (S) G51	Side	26×26×26
	1Z10×10SN			15×15×20
	1Z20×20SN			26×26×26
	2Z10×10SN			15×15×20
	2Z20×20SN			26×26×26
	5Z10×10SN			15×15×20
	5Z20×20SN			26×26×26
	10Z5× 5SN			15×15×20
	10Z10×10SN			

The couplant reserved is required to use Shear wave probe.

Order Method	Name	Model	Convergen Distance	Connector	Cable Position
(Ex)	PD	5C10/2ND	F10 mm	C25	Side



G · D

S · P

S · P

D · D

U · P / R

U · P · S

P · C

C · C

Broadband Probe

■ Straight Beam Probe / Low Frequency Probe

Name	Model	Connector		External Dimensions Φ H (mm)
		Type	Position	
PW	B0.5C20N	LEMO (S)	Side	28×50
	28N	LEMO (L)		36×60
	40N			52×70
	B1C20N	LEMO (S) G51/C25	Up/Side	26×35
	30N			34×36
	B2C10N			14×20
	20N			24×28
	B5C 5N	C25	Up	8×10
			Up/Side	8×25
		LEMO (S)/G51/C25	Up/Side	14×20
			Up/Side	14×20
	10N	LEMO (S)/G51/C25	Up/Side	14×20
B10C 5N	C25	Up	8×10	
		Up/Side	8×25	
	LEMO (S)/G51/C25	Up/Side	14×20	



0.5MHz type

Name	Model	Direct Output of Cable		External Dimensions Φ H (mm)
		Type	Position	
PWS	B5C 5N	LEMO (L)	Side	8×10
	B10C 5N			8×25
	B5C 5N	LEMO (S) BNC	Up/Side	14×25
	10N			8×25
	B10C 5N			8×25



PW

■ Immersion Probe

Name	Model	Direct Output of Cable		External Dimensions Φ H (mm)
		Type	Position	
IW	B2C10I	LEMO (L) LEMO (S) BNC	Up	14×25
	20I			24×28
	B5C 5I			8×25
	10I			14×25
	B10C 5I			8×25



PWS/IW

■ Angle Beam Probe

Name	Model	Connector		External Dimensions W L H (mm)
		Type	Position	
AW	B2C10×10A45	LEMO (S) G51/C25	Up/Back/Side	14×28×24
	A60			
	A65			
	A70			
	B5C10×10A45			
	A60			
	A65			
A70				



AW

Order Method Name - Model - Connector - Connector Position

(Ex) PW - B2C10N - LEMO(S) - Side

When you order "Immersion Probe",

Order Method Name — Model — Cable — Connector — Cable Position

(Ex) IW — B5C10I — Direct Contact, 2m — LEMO(L) — Up

G
•
D

S
•
P

S
•
P

D
•
D

U
•
P
/
R

U
•
P
•
S

P
•
C

C
•
C

Composite Probe

■ Immersion Probe

Name	Model	Direct Output of Cable		External Dimensions Φ H (mm)
		Type	Position	
IWC	B2K10I	LEMO (L) LEMO (S) BNC	Up	14×25
	20I			24×28
	B5K 5I			8×25
	10I			14×25
	B10K 5I			8×25



IWC

■ Angle Beam Probe

Name	Model	Connector		External Dimensions W L H (mm)
		Type	Position	
AWC	B5K 5× 5A45	LEMO (S) G51/C25	Up/Back	11×12×20
	A60			
	A65			
	A70			
	B5K10×10A45		Up/Back/Angle	14×28×24
	A60			
	A65			
A70				

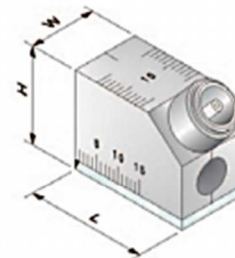

Connector Position : Angle

■ Longitudinal Wave Angle Beam Probe

Name	Model	Connector		External Dimensions W L H (mm)
		Type	Position	
AWC	B5K 5× 5LA45	LEMO (S) G51	Up/Back/Angle	14×25×20
	LA60			
	LA65			
	LA70			
	B5K10×10LA45		Up/Back	15×30×39
	LA60			
	LA65			
LA70				

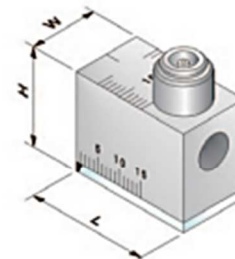

Connector Position : Up

■ Dual Element Angle Beam Probe

Name	Model	Connector		External Dimensions W L H (mm)
		Type	Position	
AWCD	B5K10×5AD45	C25	Up/Back/Angle	14×25×20
	AD60			
	AD65			
	AD70			

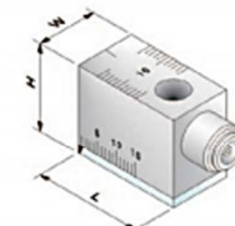

Connector Position : Back

■ Dual Element Longitudinal Wave Angle Beam Probe

Name	Model	Connector		External Dimensions W L H (mm)
		Type	Position	
AWCD	B2K20×10LAD45	LEMO (S) G51/C25	Up/Back	28×35×30
	LAD60			
	LAD65			
	LAD70			
	B5K10× 5LAD45	C25	Up/Back/Angle	14×25×20
	LAD60			
	LAD65			
LAD70				

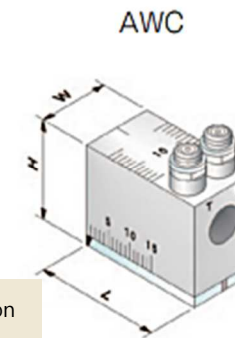

AWCD

Order Method Name - Model - Connector - Connector Position

(Ex) AWC - B5K10×10A45 - LEMO(S) - Back

When you order "Immersion Probe",

Order Method Name — Model — Cable — Connector — Cable Position

(Ex) IWC — B5K10I — Direct Contact, 2m — LEMO(L) — Up

G · D

S · P

S · P

D · D

U · P / R

U · P · S

P · C

C · C

Focusing Probe

G · D
S · P
S · P
D · D
U · P / R
U · P · S
P · C
C · C

Point Focusing Angle Beam Probe

Name	Model Specifications						Connector						
	Frequency	Element Materials	Element Dimension	Mode	Refraction Angle (°) & External Dimensions (mm)				Type	Position			
					45°		60° / 70°						
W	L	H	W	L	H								
AF	2	Z	20	A	24	35	25	24	45	27	LEMO (S) G51	Up/Back/Angle	
			25		33	45	28	33	52	33			
			30		40	52	33	40	65	40			
			35		45	65	40	45	72	45			
	40	50	70	43	50	80	50						
	5	Z	10	A	14×25×20				LEMO (S) G51	Up/Back/Angle			
			15		19	30	22	19				35	25
			20		24	35	25	24				45	27
25			33		45	28	33	52			33		
30	40	52	33	40	65	40							

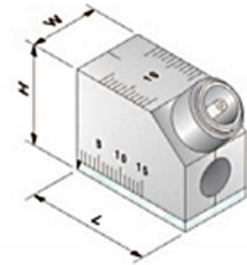

Connector Position : Angle

Point Focusing Longitudinal Wave Angle Beam Probe

Name	Model Specifications						Connector			
	Frequency	Element Materials	Element Dimension	Mode	Refraction Angle (°) & External Dimensions (mm)				Type	Position
					45° / 60°		70°			
W	L	H	W	L	H					
AF	2	Z	20	LA	30×45×45				LEMO (S) G51	Up/Back
			25		35×50×50					
			30		40×50×55					
			35		45×55×60					
			40		50×60×65					
	5	Z	10	LA	16×35×29					
			15		24×40×35					
			20		30×45×45					
			25		35×50×50					
			30		40×50×55					

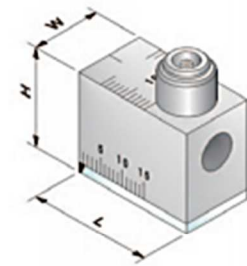

Connector Position : Up

Broadband Point Focusing Angle Beam Probe

Name	Model Specifications						Connector							
	Frequency	Element Materials	Element Dimension	Mode	Refraction Angle (°) & External Dimensions (mm)				Type	Position				
					45°		60° / 70°							
W	L	H	W	L	H									
AFC	B2	K	20	A	24	35	25	24	45	27	LEMO (S) G51	Up/Back		
			25		33	45	28	33	52	33				
			30		40	52	33	40	65	40				
			35		45	65	40	45	72	45				
			40		50	70	43	50	80	50				
	B5	K	10	A	14×25×20				LEMO (S) G51	Up/Back				
			15		19	30	22	19					35	25
			20		24	35	25	24					45	27
			25		33	45	28	33					52	33
			30		40	52	33	40					65	40

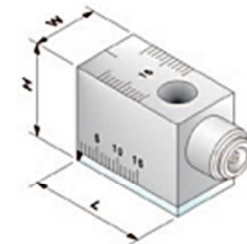

Connector Position : Back
AF/AFC

About the focal range of "AF" and "AFC", please refer to the focal range list on P13~14.

Order Method	Name	Model	Connector	Connector Position	Focal Range
(Ex)	AF	5Z10A70	LEMO(S)	Angle	SA

Focusing Probe

Point Focusing Straight Beam Probe

Name	Model Specifications						External Dimensions		
	Frequency	Element Materials	Element Dimension	Mode	Type	Position	Φ	H (mm)	
NF	2	Z	25	N	LEMO (S) G51/C25	Up/Back	30	30	
			35				36	36	
			40				40	40	
			46				40	40	
	5	Z	10	N			14	20	20
			15				18	28	
			20				24	28	
			25				30	30	
			30				36	36	

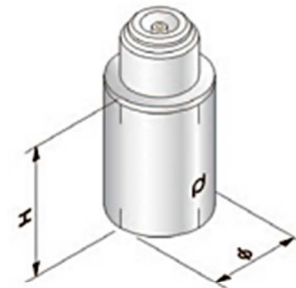

Connector Position : Up

About the focal range of "NF",
Please refer to the focal range list on P13~14.

Point Focusing Immersion Probe

Name	Model Specifications				Direct Contact of Cable		External Dimensions	
	Frequency	Element Materials	Element Dimension	Mode	Type	Position	Φ	H (mm)
IF	5	C	10	I	LEMO (L) LEMO (S) BNC	Up	14	25
			15				18	28
			20				24	28
			25				30	30
			30				36	36
	10	C	5	I			8	25

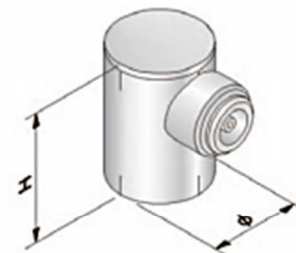

Connector Position : Side

NF

Broadband Point Focusing Immersion Probe

Name	Model Specifications				Direct Contact of Cable		External Dimensions	
	Frequency	Element Materials	Element Dimension	Mode	Type	Position	Φ	H (mm)
IF	B2	C/K	5	I	LEMO (L) LEMO (S) BNC	Up	8	25
			8				12	25
			10				14	25
	B5	C/K	5	I			8	25
			8				12	25
			10				14	25
	B10	C/K	5	I			8	25



Connector Position : Up

IF

Order Method	Name	Model	Connector	Connector Position	Focal Range
(Ex)	NF	5Z10N	LEMO(S)	Up	SB

When you order "Point Focusing Immersion Probe",

Order Method	Name	Model	Cable	Connector	Cable Position	Focal Range (Underwater)
(Ex)	IF	B5C10I	Direct Contact, 2m	BNC	Up	PF20 mm

G · D

S · P

S · P

D · D

U · P / R

U · P · S

P · C

C · C

Focal Range Data List

■ Focal Range List by Calculation for Point Focusing Probe

	Probe Specifications			Curvature List & Focal Range of Element (Depth : mm)							
	Frequency	Element Dimensions	Refraction Angle	SA(R30)	SB(R50)	SC(R70)	SD(R100)	SG(R150)	SE(R200)	SH(R250)	
Angle Beam Probe	2	20	A45		~23	~31	~40	~47			
		25				~35	~49	~64	22~73	24~79	
		30						21~52	27~75	31~90	33~101
		40							37~83	45~110	51~132
	5	10			3.5~13	5.5~21	7~26	7.6~30			
		15			6~13	10.5~25	13.5~36	17~48	20~62	22~69	24~75
		20				13~24	18~37	24~55	31~80	35.5~97	39~110
		25					21~35	29~55	40~86	48~112	52~134
	30						22~32	32~52	46~86	57~117	65.5~145
		20		A60				~22	~27		
		25						~27	10.5~36	12~41	13~45
		30						10.5~29	14~42	16~51	18~58
	35					12~29	17~45	20~58	22.5~68		
	40					13~28	19.5~46.5	24~62	27.5~75		
	10					3~12	3.5~14	4~17			
		15				5.5~14	7.5~21	9.6~28	11.5~36	12.5~40	13~44
		20					9.5~21	13~31	17~46	20~56	21.5~63
		25					11~19.5	16~31	22.5~49	27~65	30~77
	30						11~17	17~29	25.5~49	32~67	37~84
		20	A70						3~14		
25								5~18.5	6~21	3~23.5	
30							7~21	8~26.5	9~30		
35						8~23	10~30	11.5~35			
40						9.5~23.5	12~32	13.5~38.5			
10					1.5~6.5	2~8	2~9				
	15				2.5~7.5	3.5~10.5	4.5~14.5	5.5~18.5	6.5~21	7~23	
	20					5~10.5	6.5~16.5	9~24	10~29	11~33	
	25					5.5~9.5	8~16	11~25.5	13.5~33.5	15.5~40	
30								8.5~15	13~25	16~34.5	19~43.5
	25	N				15.5~28.5	18.5~39	22.5~52.5	24.5~62	26~68	
	30					17~28	21.5~40	27~58	31~72	33.5~82.5	
	35				18.5~27	24~40	31.5~60	36.5~78.4	0.5~93		
40				19.5~26	26~39	35~60.5	41.5~80.5	47~98			
10					8~18.5	9.5~23	10.5~27.5	11.5~31.5			
	15				12~20.5	14.5~28.5	17.5~38.5	21~50.5	23~59	24~64	
	20				14~19	18~28	23~40.5	29~59.5	33~75	36.5~87	
	25					20~27	26.5~40	35~61	41.5~81	47~98	
30							28~37.5	39~59.5	47.5~81	55~101	
Straight Beam Probe	2		25	N			15.5~28.5	18.5~39	22.5~52.5	24.5~62	26~68
			30				17~28	21.5~40	27~58	31~72	33.5~82.5
		35				18.5~27	24~40	31.5~60	36.5~78.4	0.5~93	
		40				19.5~26	26~39	35~60.5	41.5~80.5	47~98	
	5	10				8~18.5	9.5~23	10.5~27.5	11.5~31.5		
		15				12~20.5	14.5~28.5	17.5~38.5	21~50.5	23~59	24~64
		20				14~19	18~28	23~40.5	29~59.5	33~75	36.5~87
		25					20~27	26.5~40	35~61	41.5~81	47~98
30							28~37.5	39~59.5	47.5~81	55~101	

G · D
S · P
S · P
D · D
U · P / R
U · P · S
P · C
C · C

Performance Testing Diagram for Point Focusing Probe

Curvature List & Focal Range of Element (Depth : mm)				
SF(R300)	SI(R350)	SJ(R400)	SK(R500)	SL(R800)
35~109	37~115	38~121		
56~149	59~164	62~176	66~194	
41~119	43~126	45~133		
58~151	61~165	64~177	68.5~194	
72.5~170	78~191	83~210	90.5~240	104~293
19~62	20~66	20.5~69		
24.5~75	26~81	27~85.5	29~93	
30~85.5	32.5~94	34~101	37~112	
23~69	24~73	25~77		
33~88	35~96	36.5~103	39~113	
41~98	44~111	47~122	51.5~139	59.5~170
9.5~32	10~34	10.5~36	11~38.5	
12.5~39	13~42	13.5~44.5	14.5~48	
15~44	16~48.5	17~52	18.5~58	
12~36	12.5~38	13~40		
16.5~45.5	18~50	18.5~53.5	20~59	
21~51	22.5~57.5	24~63.5	26.5~72.5	30.5~89
27~73	28.5~77			
35.5~91	37~97	38.5~102	40.5~110	
44~104.5	46~114.5	49~122	52~135	
51~114	55~127	58~138	62.5~157	70.5~190
25~68.5	26~72			
38.5~96.5	40.5~104	42~110	44.5~119	
51~114	54.5~127	57.5~137	62~156	69.5~187
61~120	66.5~138	70.5~154	78~181	91.5~235

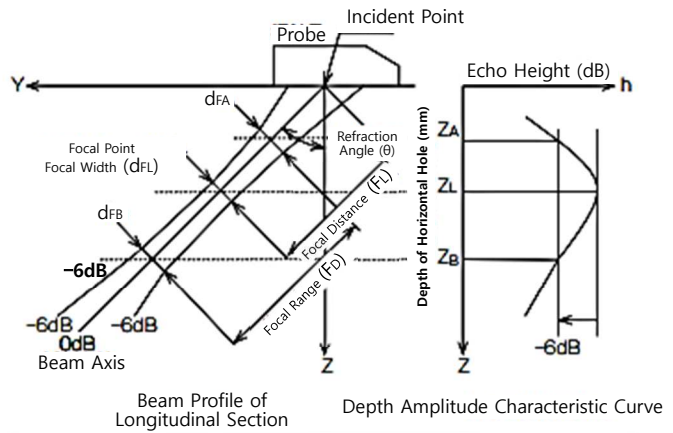

(Ex) Performance Testing Diagram of Point Focusing Angle Beam Probe

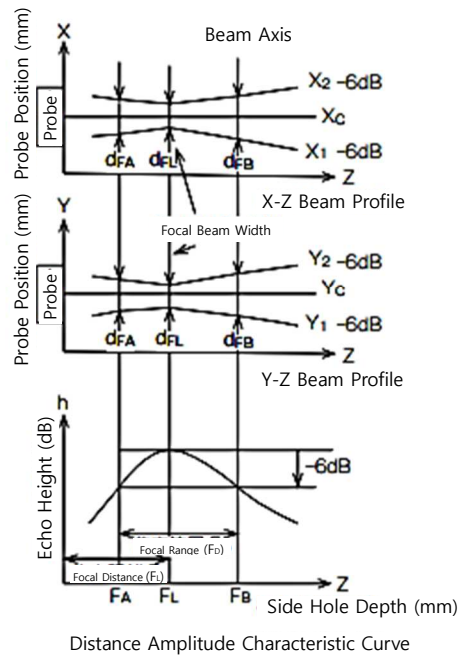

(Ex) Performance Testing Diagram of Point Focusing Straight Beam Probe

G · D

S · P

S · P

D · D

U · P / R

U · P · S

P · C

C · C

SOFT PROBE 「JUTAN」

Flat Type / Case Type / Pencil Type

Features

Soft Probe, 「JUTAN」 helps you to efficiently detect in the hard-to-access location or objects like the irregular welding zone or castings, concave and convex parts and gap with soft surfaces on the probe. It allows you to realize the safe and stable detection and measurement. Operable with commercially available ultrasonic flaw detectors.

Single Element Straight Beam

Name	Model	Connector	
		Type	Position
H	1K20N	C25	Up
	2K10N		
	20N		
	5K 3N		
	5N		
	10N		
	10K 3N		
HC	2K10N	LEMO (S) G51/C25	Up/Side
	5K 5N		
	10N		
	10K 5N		
	10N		
HP	5K 3N	C25	Up
	5N		
	10K 3N		
	5N		

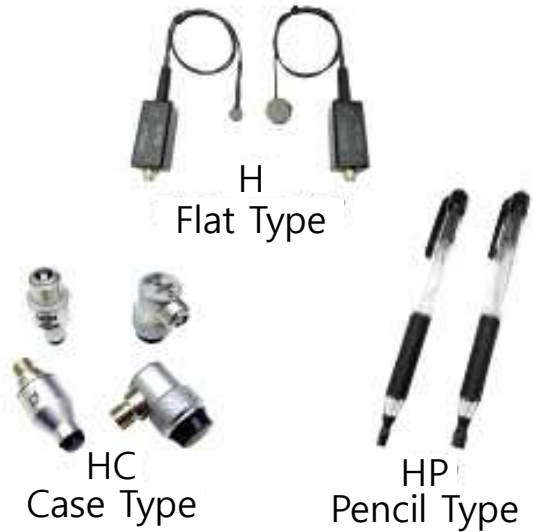

Dual Element Straight Beam

Name	Model	Connector	
		Type	Position
HD	2K10/2ND	C25	Up
	5K 5/2ND		
	10/2ND		
	10K 5/2ND		
HDC	2K10/2ND	C25	Up/Side
	5K 5/2ND		
	10/2ND		
	10K 5/2ND		
HDP	5K 3/2ND	C25	Up
	5/2ND		
	10K 3/2ND		



Detection Example

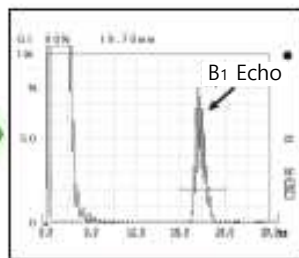

Waveform Measurement Example

SOFT PROBE 「JUTAN」

Cartridge Type

Features

Soft Probe 「JUTAN」 Cartridge Type, Simply Exchangeable for Probes Only,
It allows you to realize the optimal detection and measurement with only one probe.
Operable with commercially available ultrasonic flaw detectors.

■ Single Element Straight Beam

● Main Body

Model	Connector	
	Type	Position
Body PEN I	C25	Up
Body PEN I Hard Case		



● Cartridge Part

Name	Model
HFC	1K20N
	2K10N
	20N
	5K 3N
	5N
	10N
	10K 3N
HPC	5N
	10N
	5K 3N
	5N
	10K 3N
	5N
	5N

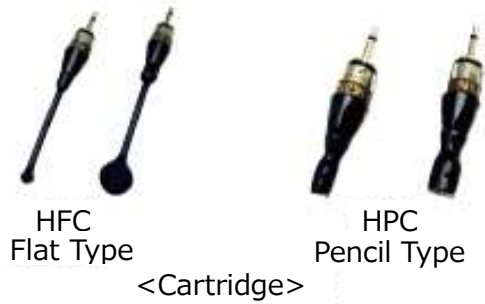

■ Dual Element Straight Beam

● Main Body

Model	Connector	
	Type	Position
Body PEN II	C25	Up
Body PEN II Hard Case		



● Cartridge Part

Name	Model
HDFC	2K10/2ND
	5K 5/2ND
	10/2ND
	10K 5/2ND
HDPC	10/2ND
	5K 3/2ND
	5/2ND
	10K 3/2ND
	5/2ND



G
•
D

S
•
P

S
•
P

D
•
D

U
•
P
/
R

U
•
P
•
S

P
•
C

C
•
C

FLEXIBLE PROBE 「TAKOTAN」

Flexible Probe 「TAKOTAN」

Features Following the slits of flexible elements, matching layer and damping materials, it allows you to realize the optimal detection and measurement to adhere to three dimensions just like octopus. Operable with commercially available ultrasonic flaw detectors.

Use

- Detection and measurement at flat, curved surface
- Suitable for welding zone, aluminum diecasting, high damping materials like CFRP
- Detection and thickness measurement of Elbow pipe

Specifications

- Type : Single or dual element straight beam
- Frequency : 2~10 MHz
- Element size : $\phi 5 \sim \phi 10$ mm
- Connector : LEMO(S) / G51 / C25
- Operating temperature : Room temperature

Single Element Straight Beam

Name	Model	Connector	
		Type	Position
TN	2K 5N	LEMO (S) G51	Up/Side
	2K10N		
	5K 5N		
	5K10N		
	10K 5N		
	10K10N		



We design the probe based on customers' demands and needs.

Dual Element Straight Beam

Name	Model	Connector	
		Type	Position
TD	2K 5 / 2ND	C25	Up/Side
	2K10 / 2ND		
	5K 5 / 2ND		
	5K10 / 2ND		
	10K 5 / 2ND		
	10K10 / 2ND		



We design the probe based on customers' demands and needs.



Detection Example



Waveform Measurement Example



Detection Example

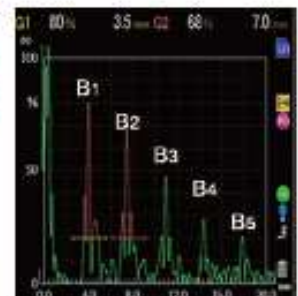

Waveform Measurement Example

Variable Angle Probe / Magnetic Probe

Variable Angle Probe

Features

Using the variable wedge, you can realize the optimal detection and measurement by switching the incident angle of ultrasound, and also add the longitudinal, shear, surface even and plate waves.

Use

- Review the optimal detection terms
- Detection under the various conditions

Specifications

- Wedge
 - Variable and available to switch an incident angle in the proper range (0°~70°)
 - Parts : Acrylic, polystyrene, polyetherimide resins
- Probe (Straight Beam Probe Only)
 - Frequency : 1, 2, 5 MHz
 - Probe Dimensions : 10X10mm, 20X20mm
 - Connector : C25

We design the probe based on customers' demands and needs.



Polyetherimide Wedge Acrylic Wedge

< Wedge (With Probe) >



Probe

Magnetic Probe

Features

You can measure and detect objects safely because it's available to use the probe while it's adsorbed on the objects as the magnetic type.

Use

- Measurement for axial forces of bolt
- For SH wave
- For Flow Rate Measurement
- When you fix the probe on objects

Specifications

- Inserting the magnet inside the probe
 - Attached outside the probe
- We design the probe based on customers' demands and needs.



Magnet Insertion Type



Magnet Attachment Type



Usage Example - 1



Usage Example - 2

G · D
S · P
S · P
D · D
U · P / R
U · P · S
P · C
C · C

Small Probe / Slim Probe

Small Probe

Features

- Ultra Slim Type (Minimum Diameter = 1.6mm)
- High Sensitivity

Use

- Measuring & Detection of the Narrow spaces
- Hydrophone

Name	Model	Direct Output of Cable		External Dimensions W L H (mm)
		Connector	Position	
UMA	5C3×3A45	LEMO(L) LEMO(S)/BNC	Up	5× 6×10
	5K3×3A45			
	10C3×3A45			
	10K3×3A45			

Name	Model	Connector		External Dimensions W L H (mm)
		Type	Position	
UMA	5C5×5A45	C25	Up	7× 8×10
	A60			7×10×10
	A70			7× 8×10
	5K5×5A45			7×10×10
	A60			7×10×10

Name	Model	Direct Output of Cable		External Dimensions Φ H (mm)
		Connector	Position	
UMS	5K1N	C25	Side	3×12
	10K1N			

Name	Model	Direct Output of Cable		External Dimensions Φ H (mm)
		Connector	Position	
UMI	5K1I	LEMO(L) LEMO(S)/BNC	Up	1.6×10
	10K1I			

We design the probe based on customers' demands and needs.



UMA
5K3×3A45



UMS
10K1N



UMI
5K1I

Slim Probe

Features

- Ultra Slim Type (Minimum Thickness = 0.8mm)
- High Sensitivity

Use

- Measuring & Detection in the restricted places with height limit

Name	Model	Direct Output of Cable		External Dimensions W L H (mm)
		Connector	Position	
UMN	5C6×4N t=0.8	LEMO(L) LEMO(S) BNC	Side	16×10×0.8
	5K6×4N t=0.8			16×10×1
	5C6×4N t=1.0			16×10×0.8
	5K6×4N t=1.0			16×10×1
	10C6×4N t=0.8			16×10×0.8
	10K6×4N t=0.8			16×10×1
	10C6×4N t=1.0			16×10×1

We design the probe based on customers' demands and needs.



UMN

5C6×4N

Detection Area : t=0.8mm

G
•
D

S
•
P

S
•
P

D
•
D

U
•
P
/
R

U
•
P
•
S

P
•
C

C
•
C

Insertion Probe / Pencil Probe

Insertion Probe

Features

It's possible to insert into the pipe and provides the reliable supply like liquid contact materials.

Use

- Straight and angle beam method from inside the pipe
- Thickness Measurement by dual element type

Specifications

- 5C5X5A45, A70
- 10C5X5A45, A70
- 5C5 / 2ND
- 10C5 / 2ND

Designing based on customers demands & needs.



Detection example from inside the pipe

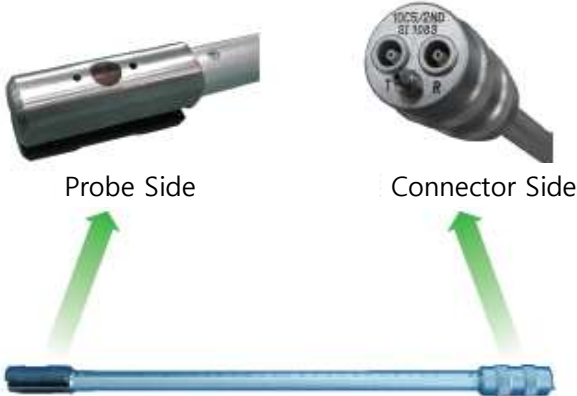

10C5/2ND

Pencil Probe

Features

This probe is for the detection of the narrow and slim area. You can select 3 kinds of probes (Straight / Hammer / Nose Type) on usage. Straight and Hammer Type is the probes for high resolution detection at 0.8mm thickness.

Use

- High Temperature Straight Beam Probe
- Poor Crimping Testing for Spot Welding
- Thickness Measurement of Resinous Container Corners
- Angle and Straight Beam Method of the Narrow

Name	Model	External Dimensions Φ (mm)
Straight Type	10K4N	2.5
Hammer Type	Fore-end Chip Switched Type	
Straight Type	15K4N	
Hammer Type	Fore-end Chip Switched Type	

We design the probe based on customers' demands and needs.

Name	Model	External Dimensions H (mm)
Nose Type	B5C5N	4
	5C3×3A45	8
	A70	8

We design the probe based on customers' demands and needs.



Nose Type

G · D
S · P
S · P
D · D
U · P / R
U · P · S
P · C
C · C

High Frequency Probe / High Temperature Probe

High Frequency Probe

Features

This is very useful for detecting microdefects as the high sensitivity and resolution probe. And, it enables you to realize the high sensitive measure detection and measurement.

Use

- Detection and Measurement of Thinner Objects
- Semiconductor Testing
- Photoacoustic Imaging
- Nonlinear Ultrasound

Specifications

- Type : Immersion
- Frequency : Max at 25MHz
- Element Size : ~ $\phi 6$

We design the probe based on customers' demands and needs.



25E6I PF14

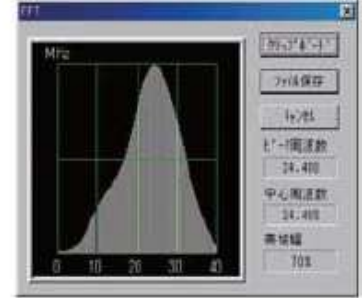

25E6I PF14

Frequency Characteristics Example

High Temperature Probe

Features

It allows you to use it to high temperature by using elements, cases, cables with heat-resistance. You can select the optimal probe by detection and measurement method.

We design based on customers' demands and needs even about the measurement using the wave guide.

High Temperature Straight Beam Probe

(Usual Temperature : Until 150°C)

Name	Model	Connector		External Dimensions Φ H (mm)
		Type	Position	
PH	2C6N	C25	Up	14×31



PH

(Usual Temperature : Until 500°C)

Name	Model	Direct Output of Cable		External Dimensions Φ H (mm)
		Connector	Position	
PHU	6M8N	LEMO(L)/BNC	Up	16×38



PHU

You can select one of cable resisting heat up to 300°C or 500°C.

Please select the electrode protection plate used during measurement from stainless steel or silver.

High Temperature Dual Element Straight Beam Probe

Name	Model	Connector		External Dimensions Φ H (mm)
		Type	Position	
PHD	5C10 / 2ND	C25	Up	18×40

(Usual Temperature : Until 150°C)



PHD

High Temperature Angle Beam Probe

(Usual Temperature : Until 120°C)

Name	Model	Connector		External Dimensions W L H (mm)
		Type	Position	
PHA	5C10×10A45	LEMO(S) G51	Up	24×30×20
	A70			



PHA

We also carry the high temperature cable and wedge.

We offer the optimal products based on customers' demands and needs.

G
·
D

S
·
P

S
·
P

D
·
D

U
·
P
/
R

U
·
P
·
S

P
·
C

C
·
C

Pressure Resistant Probe

Pressure Resistant Probe (Patent No. 5552658)

Features

By getting the pressure balance type, we make the probe withstanding the high pressure under the sea.

Use

- Frequency : 100kHz~2MHz
- Element : 1-3 Composite Element
- Pressure Resistance : ~300

Example

- Array Probe withstanding the high pressure under 3,000m below sea
 - 5 channels transmitting, Annular Array (2MHz)
 - 2 channels receiving, Cross Array (200kHz)
 - Case (Upper Part=SUS316, Lower Part=Acrylic Resins)
 - Rubber balloon for Pressure Regulation Protection Cover, etc.



Probe for Seabed Mining Discovery
(Under 3,000m below sea)

Thickness Measurement of Seabed Rare Metal by Using this Probe

- We measured the thickness of rare metal (manganese crust) found under the sea, by transmitting and receiving the ultrasonic signals of 1m away from the seabed. (under 3,000m below sea)
 - ※ Joint Research by Prof. Akira Asada (Tokyo University) and JAMSTEC

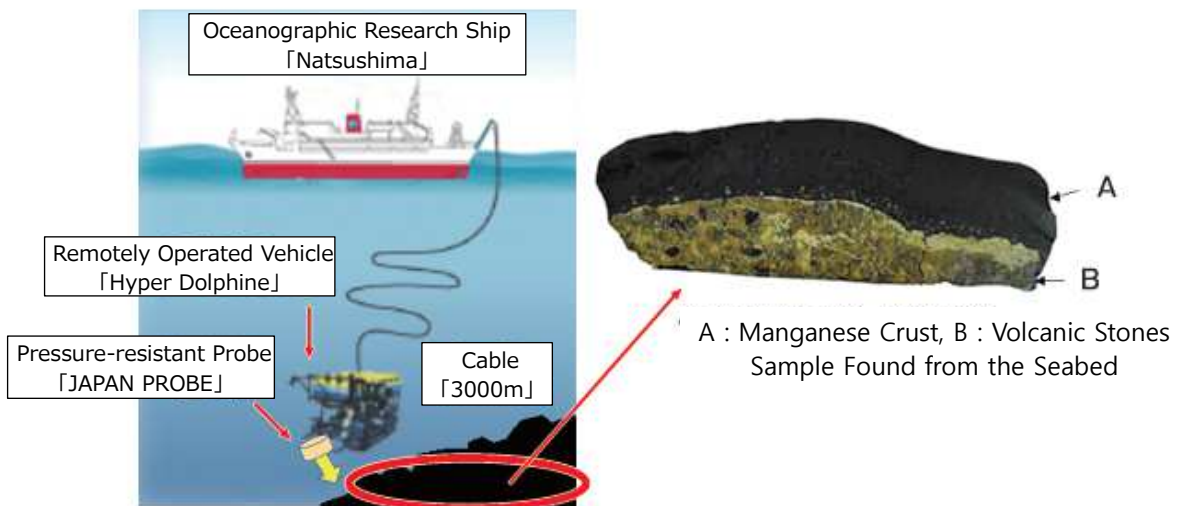

Measurement Example

JAMSTEC
[Japan Agency for Marine-earth Science & Technology]

G
·
D

S
·
P

S
·
P

D
·
D

U
·
P
/
R

U
·
P
·
S

P
·
C

C
·
C

Tire Probe

Single Element Fixed Type

Features

It allows you to realize the straight beam and angle beam detection by exchanging the internal probe for with tire. It allows you to realize the continuous detection by straight beam, angle beam, and plate wave with a little bit couplant. Besides, it allows you to apply suitably even in the rough faces.

Use

- By Transmission Method, Continuous Testing
- Continuous Detection for Connection Parts of Honeycomb Board
- Continuous Detection of Thin Plate by Plate Wave & Defect Checking by Transmission Method

Specifications

- Frequency : 2~5MHz
- Element Dimensions : ϕ 5~10mm

We design the probe based on customers' demands and needs.

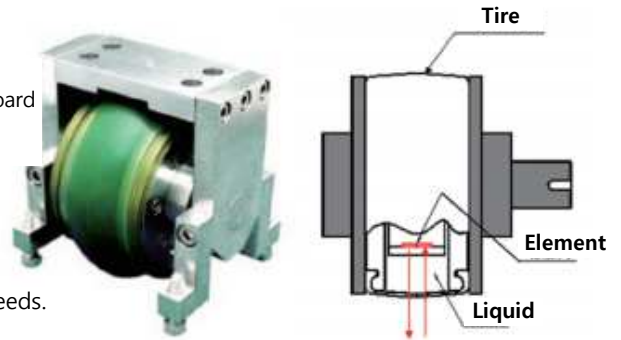

Tire Probe Single Element Fixed Type

Dual Element Fixed Type

Features

It is available to continuously detect the defects right under the surface online. It allows you to continuously detect and measure the corrosion from the thin plate to the thick plate by changing the angle and frequency of the internal probe with tire.

Use

- Continuous Detection by Straight Beam Method
- Continuous Measurement for Inside Corrosion
- Defect Checking

Specifications

- Frequency : 2~5MHz
- Element Dimensions : ϕ 10mm

We design the probe based on customers' demands and needs.

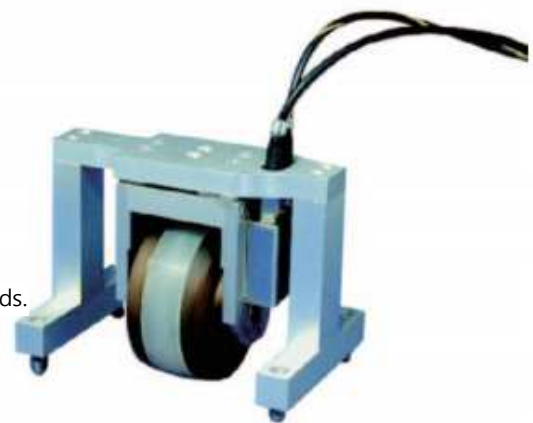

Tire Probe

G
·
D

S
·
P

S
·
P

D
·
D

U
·
P
/
R

U
·
P
·
S

P
·
C

C
·
C

Jig / Wedge / Couplant

Jig



Jig for TOFD



Jig for Probe Connections



Jig for Detection/Measurement



Jig for Pipe Detection



Jig for Round Bar Detection



Jig for NAUT21

Wedge



Polystyrene Material



High Temperature Applications (SX Material)



Flanging Type



For Array Probe



Screw Filler Type



For Variable Angle

Besides, we offer the optimal products based on customers' demands and needs.

Couplant

Model

- For Straight & Angle Beam Probe
- For Shear Wave & SH Wave
- For Concrete Detection
- For High Temperature Detection

We offer the optimal products based on customers' demands and needs.

G • D
S • P
S • P
D • D
U • P / R
U • P • S
P • C
C • C

Ultrasonic Array Probe

Ultrasonic Array Probe

Features

We can offer each kinds of experimental and research probes by 1-3 composite elements on our own with high sensitivity



1-3 Composite Structures

Model

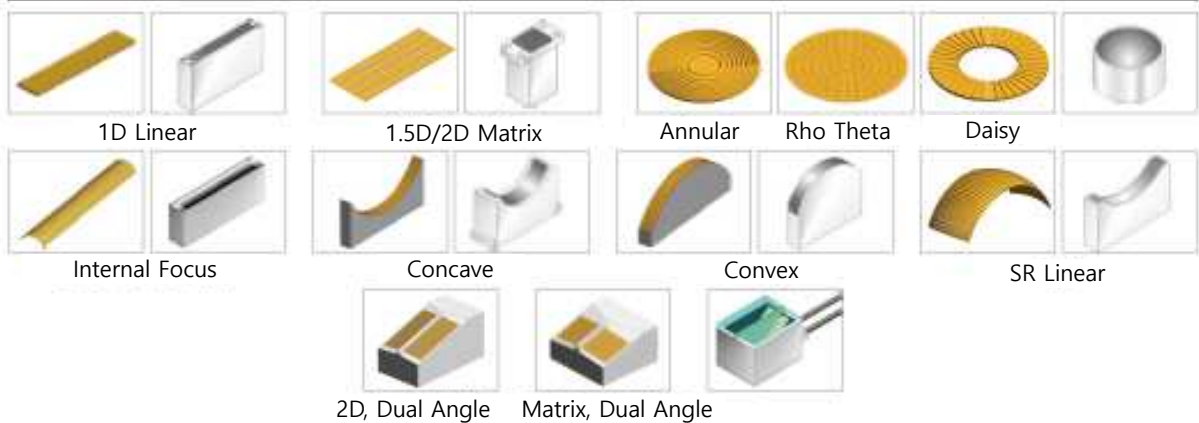

Element Model & Waveform

- Element Type: 1-3 Composite Element
- Waveform: Broadband, Minimizing Variation in Sensitivity
- Detection: All of Waveform

Specifications

- Frequency : 50kHz ~ 15MHz
- Element Numbers : 8~1024 (Specialty Items)

Connector

- HYPERTRONICS / TYCO / IPEX / ITT Canon
- ※ Besides, we also carry the special connector.

Cable

Multicore Coaxial Cable : ~ 128CH
Track No. : #30, #36, #40
Besides, we also carry the radiation Tolerant & Robot Cable.

High Temperature Applications

High Temperature Design Specifications for 120°C
※ Including Wedge Materials

Quality

Advanced Micro Soldering by skilled workers

Related Product to Array Probe

Conversion & Extension Cable

- Connector & Receptible
HYPERTRONICS / TYCO / IPEX / ITT Canon
- Cable
Multicore Coaxial Cable (~128CH)
- ※ Besides, we also carry the special wiring.

Wedge

- Materials
Polystyrene / Acryl / SX Materials (For High Temperature)
Polyetherimides / etc.



HYPERTRONICS / TYCO
Conversion

G
·
D

S
·
P

S
·
P

D
·
D

U
·
P
/
R

U
·
P
·
S

P
·
C

C
·
C

Ultrasonic Array Probe

Flexible Linear Array Probe (KYOKUTAN)

Features

- This probe is made with the flexible materials and it's available to detect the curved surface, concave and convex parts, gap, even and rough faces in various types of objects.
- It's available to detect the defects right under the surface, proximity defects, CFRP, GFRP, aluminum alloy for diecastings, welding zone, etc.
- It is used for both Industrial application as well as Medical research and Development.

Specification

- Frequency : 1~10MHz
- Element : Linear Arrangement, 8~256 Elements
- ※ About matrix arrangement, please feel free to contact us.
- Flexibility : R=5mm
- Category Temperature Range : Room Temperature
- ※ If you have additional questions, please do not hesitate to contact us.



「KYOKUTAN」



「KYOKUTAN」 Protrusion Usage Example

Flexible Matrix Array Probe (TAKOTAN)

Features

- For HIFU (High Intensity Focused Ultrasound) therapy ;]
 - The tumor is ablated (cauterized) with ultrasonic waves.
 - HIFU irradiation in healthy tissues is reduced.
- For receiving sensor of Photoacoustic imaging system, etc.

Specifications

- Type : Rho Theta Phased Array
- Frequency : 1~15MHz
- Element type : 1-3 Composite
- Element numbers : ~ 1,024 elements
- Connector : Compatible with various connectors
- ※ If you have additional questions, please do not hesitate to contact us.



「Array Transducer for HIFU」



「Element arrangement」

G
·
D

S
·
P

S
·
P

D
·
D

U
·
P
/
R

U
·
P
·
S

P
·
C

C
·
C

Non-contact Air Coupled Ultrasonic Testing

NAUT : Non-contact Air coupled Ultrasonic Testing - Held over Patent No. 4903032

Features Non-contact Air coupled Ultrasonic Testing is the innovative system realized through the ultrasonic technique and experiences built up for years by JAPAN PROBE. It allows you to realize the detection / measurement / evaluation / analysis.

NAUT Features

- **Ultrasonic Pulsar/Receiver**
Transmitting the electric signal of the strong burst waves
- **Air Probe**
Possible to transmit and receive the ultrasonic wave
- **Preamplifier**
- **Control PC**

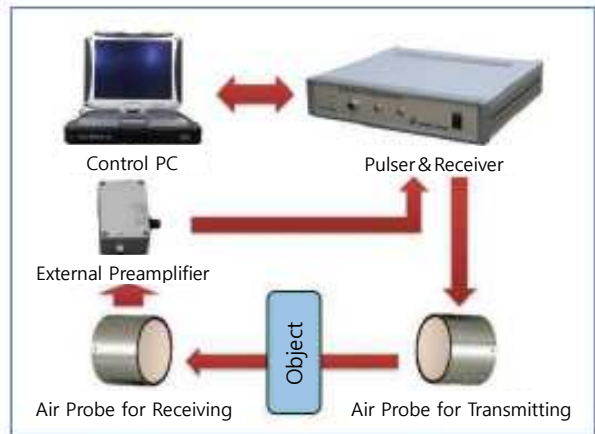

NAUT Configuration

Applications

Transmission Method

NAUT as Typical Method Testing inside the Object

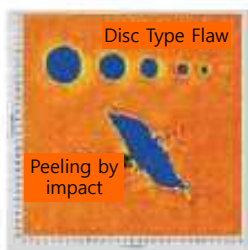
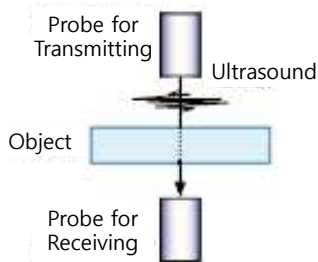

Image for CFRP Detection

Single-side Transmission Method

NAUT Detecting or Measuring inside and back-side of the Object

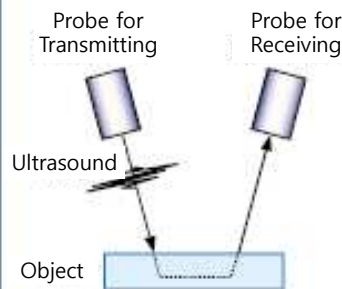

Image for Hole Detection of Box back side

Reflection Method

NAUT for the Surface Detection / Measurement using One Air Probe

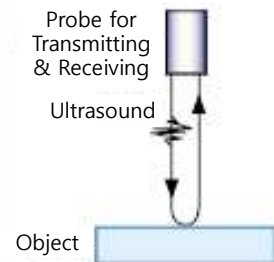

Image for Coin Surface Measurement

Detection/Measurement Example by NAUT21

G
·
D

S
·
P

S
·
P

D
·
D

U
·
P
/
R

U
·
P
·
S

P
·
C

C
·
C

Non-contact Air Coupled Ultrasonic Testing

NAUT21 Solution examples

NAUT21 Solution examples



(Left: Image after impact test, Center: Image after lightning strike test, Right: Image after tensile test)



LIB (Lamination type)

LIB (Square type)

LIB (seal part of Lamination type)

(Left: Specimen, Right: Image by NAUT21) (Left: Specimen, Right: Image by NAUT21) (Left: Specimen, Right: Image by NAUT21)

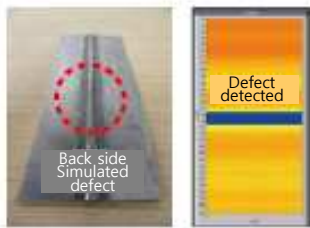

Butt welded of Steel plate

(Left: Specimen, Right: Image by NAUT21)

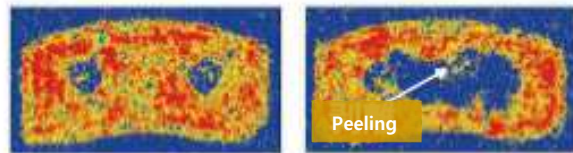

Brake Pad for Automobile - Image by NAUT21

(Left: Image of good brake pad, Right: Image of defective one)

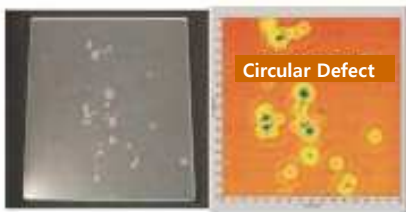

Contact Surface of Acrylic Resin

(Left: Specimen, Right: Image by NAUT21)



Tire

(Upper: Specimen)
(Lower: Image by NAUT21)

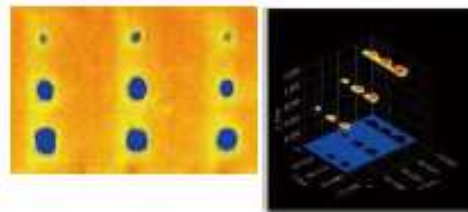

NAUT21-I Image

(Left: Planar image by air coupled method)
(Right: 3D image by immersion method)

G · D
S · P
S · P
D · D
U · P / R
U · P · S
P · C
C · C

Non-contact Air Coupled Ultrasonic Testing

NAUT21 Software / NAUT21 Line up & Customizations

■ NAUT21 Software

- JP Original Software as the Native Attachment Software OS Environment : Windows 7 / 10 / 11
- Providing the device control "DLL" in options Using "DLL", it allows you the software development on your own.
- DLL : The software below is available.
 - LabVIEW
 - MATLAB
 - Python
 - VB
 - VC



NAUT21 Main GUI

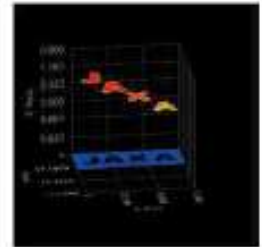

Cross Section 3D image (NAUT21-I)

■ NAUT21 Line up



NAUT21 (Standard Type)



NAUT21-V (Vertical Type)



NAUT21-R (Rotating Type)



NAUT21-M (High Speed Type)

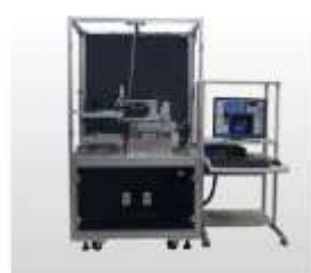

NAUT21-I (Air-Coupled & Immersion Type)

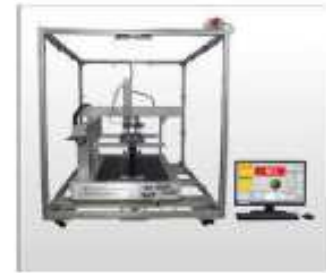

NAUT21-S (Single-side Type)

■ NAUT21 Customizations



Example:
7-axis Configuration

We provide customization of NAUT21 according to customer's needs such as Probe, Mechanism and Software.

We also manufacture Immersion type test equipment. Please feel free to contact us first.

G
·
D

S
·
P

S
·
P

D
·
D

U
·
P
/
R

U
·
P
·
S

P
·
C

C
·
C

Air Probe

Features

By the development of the air-friendly matching layer, high sensitive air probe allows you to transmit the ultrasound efficiently in the air. It's available to apply for the high damping materials or high-resolution imaging, Frequency at 50kHz~2MHz

Flat Type (High Sensitivity)

Name	Focus/ Non Focus	Model	Connector		External Dimensions		
			Type	Position	W	L	H (mm)
HAR	Flat	0,05K25×25N	LEMO (S) G51/C25	Up	35	35	70
		50×50N			60	60	70
		0,1K25×25N			30	30	45
		50×50N			60	60	60
		0,2K14×20N			17	23	33
		25×25N			30	30	30
		0,4K14×20N			17	23	30
		20×20N			30	30	30
		0,8K10×10N			15	15	30
		14×20N			17	23	30
		1K10×10N			15	15	30
		14×20N			17	23	30
		2K10×10N			15	15	30



Flat Type

We design the probe based on customers' demands and needs.

Line Focus Type (High Sensitivity)

Name	Focus/ Non Focus	Model	Connector		External Dimensions		
			Type	Position	W	L	H (mm)
HAR	Line Focus	0,2K20×14N R 50	LEMO (S) G51/C25	Up	27	18	33
		40×20N R100			47	24	34
		60×20N R100			69	24	36
		0,4K20×14N R 50			27	18	33
		40×20N R100			47	24	34
		60×20N R100			69	24	36
		0,8K20×14N R 50			27	18	33
		40×20N R100			47	24	34
		60×20N R100			69	24	36



Line Focus Type

We design the probe based on customers' demands and needs.

Point Focus Type (High Sensitivity)

Name	Focus/ Non Focus	Model	Connector		External Dimensions	
			Type	Position	φ	H (mm)
HAR	Point Focus	0,2K20N R20	LEMO (S) G51/C25	Up	30	30
		20N R30				
		20N R40				
		20N R50				
		0,4K20N R20				
		20N R30				
		20N R40				
		20N R50				
		0,8K20N R20				
		20N R30				
		20N R40				
		20N R50				
		1K20N R20				
2K20N R20						



Point Focus Type

We design the probe based on customers' demands and needs.

- G · D
- S · P
- S · P
- D · D
- U · P / R
- U · P · S
- P · C
- C · C

Ultrasonic Pulser & Receiver

Ultrasonic Pulser & Receiver - JPR Series, Held over Patent No. 5303100

Features

- Output Pulse Type : Square Pulse • Burst • Chirp / Spike
- Frequency : Low Frequency = More Than 20kHz,
High Frequency = Less Than 25MHz
- Wave Number : 1 ~ 300
- Output Pulse Voltage : Possible for 10V ~ 1800V
- Control : Changing Default Settings, Getting & Saving
Waveform on PC

Model

MODEL	FEATURES
JPR-600C	High Power (Standard)
JPR-10CN	High Power (Basic)
JPR-1800C	High Voltage
JPR-10A	Analog Pulser
JPR-50P	High Frequency
JPR-50SD	High Frequency (Compact)
JPR-10C-4CH	Multi-channel (4 CH)
JPR-10C-8CH	Multi-channel (8 CH)

Improving each product as the advanced portable type (Storage in cases specially designed, Adding Control PC in options)

Multi pulser allows channel numbers aside from them on the preceding page to be available to apply.

For further information, please contact us online at, <https://www.jp-probe.com/en/contact/index.html>

Software

- JP Original Software as the Native Attachment Software OS Environment : Windows 7 / 10 / 11
- Providing the device control "DLL" in options Using "DLL", it allows you the software development on your own.
- DLL : The software below is available.
 - LabVIEW
 - MATLAB
 - Python
 - VB
 - VC

※ We also undertake the development of software in line with customers' measurement systems. Please feel free to contact us.

Usage Example

Non-contact Air coupled Ultrasonic Testing(NAUT), Immersion Testing, Nonlinear Detection, Flow Rate Measurement, Guided Wave (Sheet Metal/Pipe/Rail), EMAT, Testing & Detection of High Damping Materials, Concrete Detection, Ultrasound Study, Teaching Materials, etc.



JPR-600C



JPR-50SD



Portable Pulser & Receiver

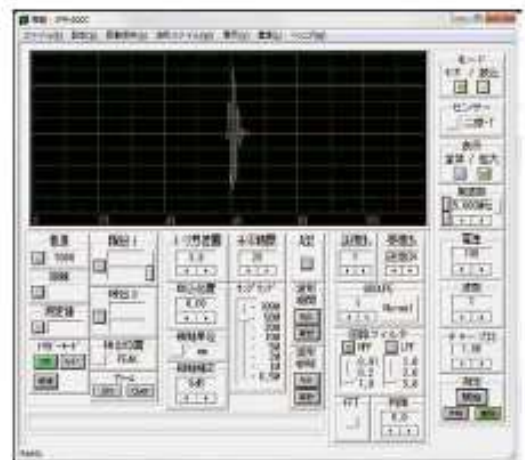

JP Original Software

Ultrasonic Propagation Simulator

Ultrasonic Propagation Simulator 「SWAN21」

Features SWAN21 (Sonic Wave ANalysis21) visualizes ultrasound propagation through simulation. It does not only allow you to conduct solid, gas, liquid, & biomedical analysis, but also support the pre-review of inspection or measurement method and product development process.

Outline

Simple control by GUI (Graphical User Interface), modeling, waveform analysis and so on with the mouse. Simulations can be performed from the beginning.

Realizes high-speed by parallel computing using GPU (Graphical Processing Unit) and multiple CPU cores. Analyzed by EFIT (Elastodynamic Finite Intergration Technique)

※1 : Parallel Computing Method proposed by Prof. Kazuyuki Nakahata (Ehime University)

Use

- Ultrasonic Propagation Analysis of ;
 - Longitudinal wave (P-wave), Shear wave (SH-wave), Guided wave, surface wave.
 - Fluids (in water, air-cupled). • Vertical/Angle flaw detections
 - Reflection, refraction, diffraction, direct waves, edge waves, etc.
 - Various methods like V transmission / tandem / TOFD method, etc.
- Array probe evaluation, focused ultrasound analysis and focus evaluation, etc.

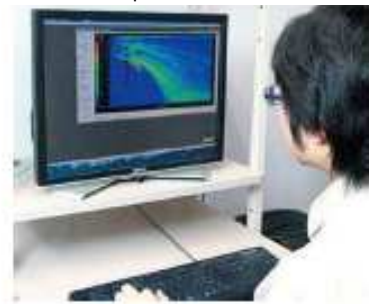

Usage Example



1. Modelling

Arrange the Source of Measurement and Element

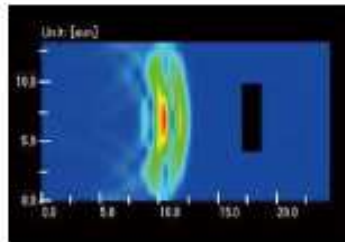

2. Simulation

Display the Image of Ultrasonic Propagation

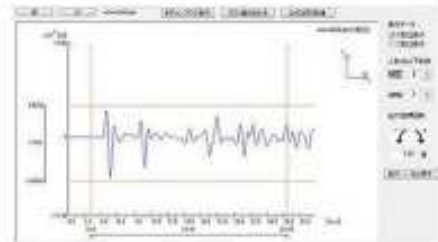

3. Result

Simulation Result, Saving Image, Display the Waveform of Output Point

Modeling & Simulation Example



Weld Bead



Butt Weld
(Image of Guided wave)

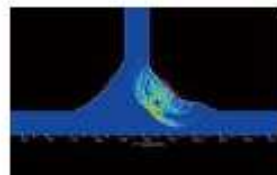

Fillet Weld

※ Development Company : eCompute Corporation

G
•
D

S
•
P

S
•
P

U
•
P
/
R

D
•
D

U
•
P
•
S

P
•
C

C
•
C

Probe Cable

When you order, please specify the type of connector and cable, even and cable length.

Order Example

Connector Type on Device Side	-	Connector Type on Probe Side	Length
LEMO (L)	-	Gp	2m

Connector

Please, specify the specifications of probe and connector on either side of device side.

Connector Type List



※ We also carry L type connector. If you have any questions at all, please contact us online at <https://www.jp-probe.com/en/contact/index.html>

※ We also carry Receptacle connector.

※ Please, contact us to inquire about them beyond the connectors above.

Cable Type

Use of Standard Type : 1.5D-XV

In case of C25 : RG174/U

Besides, we carry the flexible and double shield type, etc.

Cable Length

Standard : 2m

You can also specify the cable length.

G
·
D

S
·
P

S
·
P

D
·
D

U
·
P
/
R

U
·
P
·
S

P
·
C

C
·
C

Conversion Connector

When you order, please let us know the designated number or model name.

Order Method

Designated Number	Model
01	LEMO (L) Male — BNC Female

Conversion Connector List

		
01 LEMO, L(Male) — BNC (Female)	02 LEMO, L(Male) — LEMO, S(Female)	03 LEMO, L(Male) — M(Female)
		
04 LEMO, L(Male) — G(Male)	05 LEMO, L(Male) — C25(Female)	
		
06 M(Male) — BNC(Female)	07 M(Male) — LEMO, S(Female)	08 M(Male) — LEMO, L(Female)
		
09 M(Male) — G(Male)	10 M(Male) — C25(Female)	
		
11 BNC(Male) — LEMO, L(Female)	12 BNC(Male) — LEMO, S(Female)	13 BNC(Male) — M(Female)
		
14 BNC(Male) — G(Male)	15 BNC(Male) — C25(Female)	
		
16 LEMO, S(Male) — BNC(Female)	17 LEMO, S(Male) — LEMO, L(Female)	

C25=Micro Dot

※ Please, contact us to inquire beyond the connectors above.

G
·
D

S
·
P

S
·
P

D
·
D

U
·
P
/
R

U
·
P
·
S

P
·
C

C
·
C

2023.07

 **JAPAN PROBE Co., Ltd.**

JP Bldg., 1-1-14 Nakamura-cho, Minami-ku, Yokohama-shi,
Kanagawa-ken, 232-0033, Japan

TEL: +81-45-242-0531 FAX: +81-45-242-0541

URL: <https://www.jp-probe.com/en/>

E-mail: info@jp-probe.com